

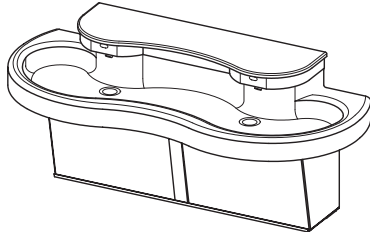

INSTALLATION INSTRUCTIONS DOUBLE AND TRIPLE STATION SENSOR OPERATED SOLID SURFACE LAVATORY SYSTEMS

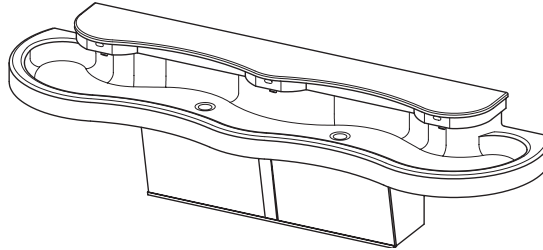

EW-42000
Double Station
Solid Surface Lavatory System



EW-43000
Triple Station
Solid Surface Lavatory System

EW-42000
Double Station
Sensor Operated
Solid Surface Lavatory System

EW-43000
Triple Station
Sensor Operated
Solid Surface Lavatory System

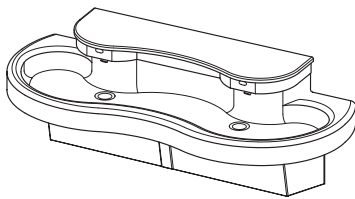

EW-42000
Double Station
Solid Surface Lavatory System
(with Juvenile Height Cabinet)

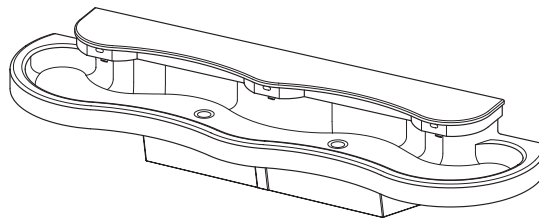

EW-43000
Triple Station
Solid Surface Lavatory System
(with Juvenile Height Cabinet)

Made in the U.S.A.

Installation of Sloan Optima EW-40000 Series Solid Surface, sensor operated lavatory systems make wash-up totally "hands-free," providing the ultimate in sanitary protection and automatic operation. The lavatory systems use infrared technology to sense the user's presence and turn on a water supply that has been pre-mixed to the desired water temperature. When the user's hands are removed from the invisible beam of light, the water supply automatically turns off.

Optima EW-40000 Series Lavatory Systems are designed for easy installation and maintenance. All system components are pre-plumbed and assembled at the factory. Optima EW-40000 Series Lavatory Systems come complete with Optima

sensors (including 24 VAC solenoid valves and transformer), spray heads, and can be supplied with juvenile height cabinet, thermostatic mixing valve and soap dispenser.

The following instructions will serve as a guide when installing the Sloan Optima Lavatory System. As always, good safety practices and care are recommended when installing your new Lavatory System. If further assistance is required, contact your nearest Sloan Representative office or the Sloan Installation Engineering Department.

LIMITED WARRANTY

Sloan Valve Company warrants its Optima EW-40000 Series Lavatory Systems to be made of first class materials, free from defects of material or workmanship under normal use and to perform the service for which they are intended in a thoroughly reliable and efficient manner when properly installed and serviced, for a period of three years (1 year for special finishes) from date of purchase. During this period, Sloan Valve Company will, at its option, repair or replace any part or parts which prove to be thus defective if returned to Sloan Valve Company, at customer's cost, and this shall be the sole remedy available under this warranty. No claims will be allowed for labor, transportation or other incidental costs. This warranty extends only to persons or organizations who purchase Sloan Valve Company's products directly from Sloan Valve Company for purpose of resale.

THERE ARE NO WARRANTIES WHICH EXTEND BEYOND THE DESCRIPTION ON THE FACE HEREOF. IN NO EVENT IS SLOAN VALVE COMPANY RESPONSIBLE FOR ANY CONSEQUENTIAL DAMAGES OF ANY MEASURE WHATSOEVER.

LAVATORY SYSTEM ROUGH-IN

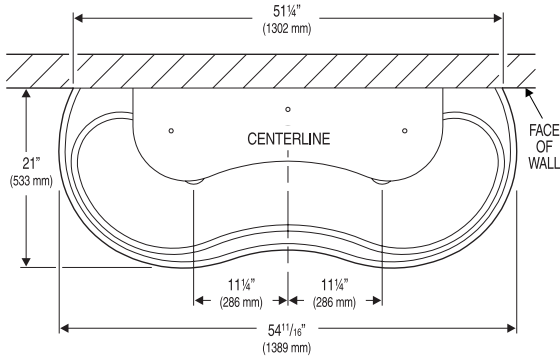

Double Station Lavatory System

MODEL EW-42000 — 0.5 gpm (1.9 Lpm) Max. — Aerator

LAVATORY SYSTEM WEIGHT (Empty) — 190 Lbs. (86 Kg)

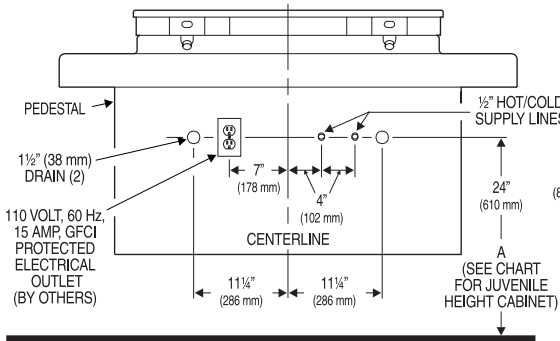

Standard Height Cabinet

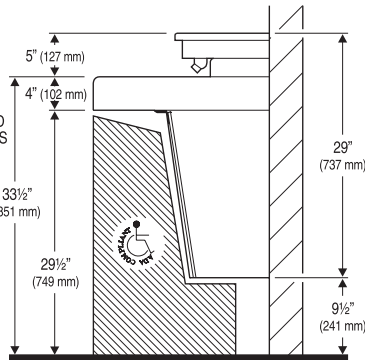

Juvenile Height Cabinet

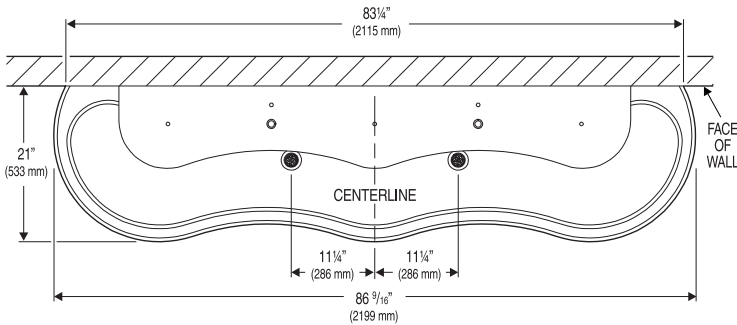
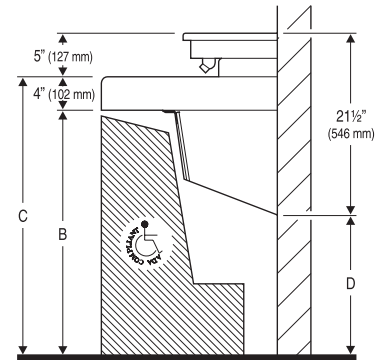

Triple Station Lavatory System

MODEL EW-43000 — 0.5 gpm (1.9 Lpm) Max. — Aerator

LAVATORY SYSTEM WEIGHT (Empty) — 250 Lbs. (113 Kg)

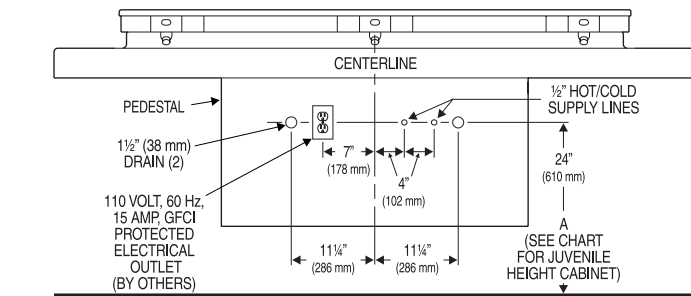

Standard Height Cabinet

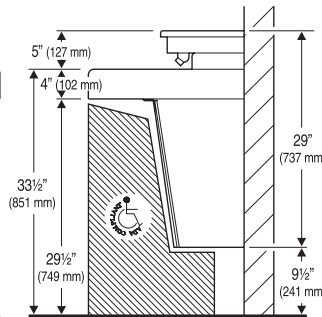

Juvenile Height Cabinet

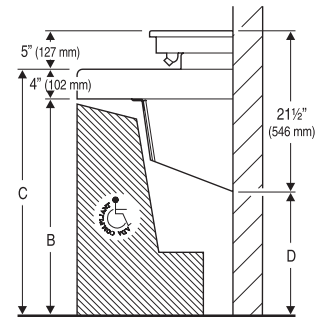

VARIABLE MOUNTING HEIGHT CHART

	DIMENSION DESCRIPTION	Texas Accessibility Standard (T.A.S.) AGES 4-10	Texas Accessibility Standard (T.A.S.) AGES 11-15	American Disability Act (A.D.A.) STANDARD
A	ROUGH-IN	20 1/2" (521 mm)	22 1/2" (572 mm)	24" (610 mm)
B	KNEE CLEARANCE	26" (660 mm)	28" (711 mm)	29 1/2" (749 mm)
C	RIM HEIGHT	30" (762 mm)	32" (813 mm)	33 1/2" (851 mm)
D	TOE CLEARANCE	13 1/2" (343 mm)	15 1/2" (394 mm)	17" (432 mm)

PRIOR TO INSTALLATION

Prior to installing the Sloan Optima EW-40000 Series Lavatory System, install the items listed below. Also, refer to the appropriate rough-in diagram on Page 2.

- **When Using Plug-In Transformer** — Install electrical receptacle(s) for plug-in transformer(s) — 120 VAC, 2 amp service for each ETF-233 (24 VAC, 35 VA) plug-in transformer used.
- **When Using Box Mount Transformer** — Install electrical wiring to the transformer location — 120 VAC, 2 amp service for each standard EL-248-40 (24 VAC, 40 VA) or EL-154 (24 VAC, 50 VA) transformer used.
- Hot and cold water supply lines or tempered water supply line
- Drain lines

Important:

- *ADEQUATE STRUCTURAL SUPPORT IN OR BEHIND THE WALL IS REQUIRED. REFER TO THE APPROPRIATE ROUGH-IN DIAGRAM ON PAGE 2 FOR DRY WEIGHT OF SINK. STRUCTURAL SUPPORT MUST HAVE A MINIMUM PULLOUT RATING OF 1000 POUNDS (450 Kg).*
- *ALL ELECTRICAL WIRING SHOULD BE INSTALLED IN ACCORDANCE WITH NATIONAL/LOCAL CODES AND REGULATIONS.*
- *ALL PLUMBING SHOULD BE INSTALLED IN ACCORDANCE WITH APPLICABLE CODES AND REGULATIONS.*
- *A 24 VAC STEP-DOWN TRANSFORMER MUST BE USED FOR HARDWIRE APPLICATIONS.*
- *USE APPROPRIATE PRECAUTIONS WHILE CONNECTING TRANSFORMER TO 120 VAC POWER SOURCE.*

- *DO NOT PLUG TRANSFORMER INTO POWER SOURCE (RECEPTACLE) UNTIL ALL WIRING IS COMPLETED. PERMANENT DAMAGE TO THE TRANSFORMER AND CIRCUIT CONTROL MODULE WILL RESULT IF 24 VAC WIRES TOUCH EACH OTHER OR SHORT WHEN POWER SUPPLY IS ACTIVE.*
- *BEFORE CONNECTING FLEX HOSES TO SUPPLY STOPS, FLUSH ALL WATER LINES UNTIL WATER IS CLEAR.*

TOOLS REQUIRED FOR INSTALLATION

- Electric drill for drilling anchor holes.
- Socket or open end wrench for installing anchoring fasteners.
- Open end wrench for connecting water lines.
- Pipe wrench for installing drain lines.

SINK LOCATION

Determine the appropriate wall location for the Lavatory System. Consider that hot and cold water supply lines, a drain line, and an electrical source (receptacle or wiring depending on type of transformer used) will be required. For Cabinets with slide out panels, leave enough room on each side of the Cabinet for panel removal. Compare the physical dimensions of the Lavatory System to the space available for the installation. If wall is not load bearing, a carrier may be required behind the wall. Refer to the appropriate Rough-in diagram on Page 2 for Lavatory System dimensions. Prior to Lavatory System installation, electric wiring, water supply and drain must be installed.

INSTALLATION INSTRUCTIONS

Step 1 — Cabinet Mounting

- Remove plastic protective coating from all stainless parts before installation.
- Measure and mark vertical centerline of lavatory system on wall.
- Determine desired cabinet height. Using rough-in diagrams on page 2, identify the type of cabinet being installed. When installing a juvenile cabinet, be sure to identify the proper clearance required between bottom of cabinet and finished floor. (Refer to variable mounting height chart at bottom of page 2). Once the dimension between finish floor and bottom of cabinet is determined, mark the wall at that height.
- With help of an assistant, lift pedestal against wall, aligning bottom of cabinet with mark made on wall. Align Center hole of cabinet with vertical centerline on wall. Level cabinet, then mark or drill holes in wall through all mounting holes located on back of cabinet.
- Secure Cabinet to wall using wall anchors that are specific for that type of wall: drywall, concrete, metal studs, wood studs, etc. (supplied by installer).

Step 2 — Strainer Installation

- Insert strainer into Basin using plumbers putty (supplied by installer).
- From beneath basin, install the rubber gasket, cardboard seat and drain nut onto strainer. Secure drain nut against Basin.

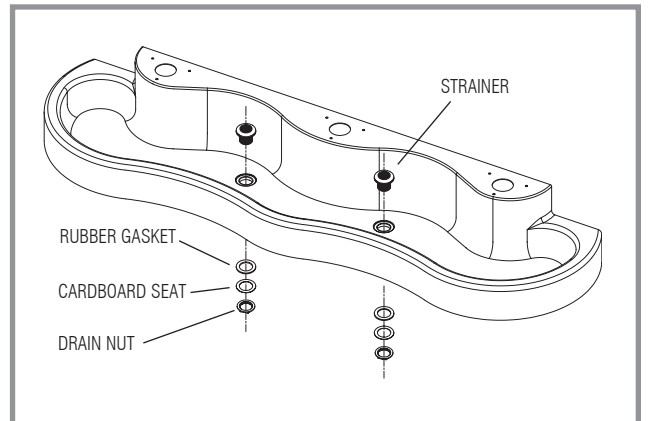
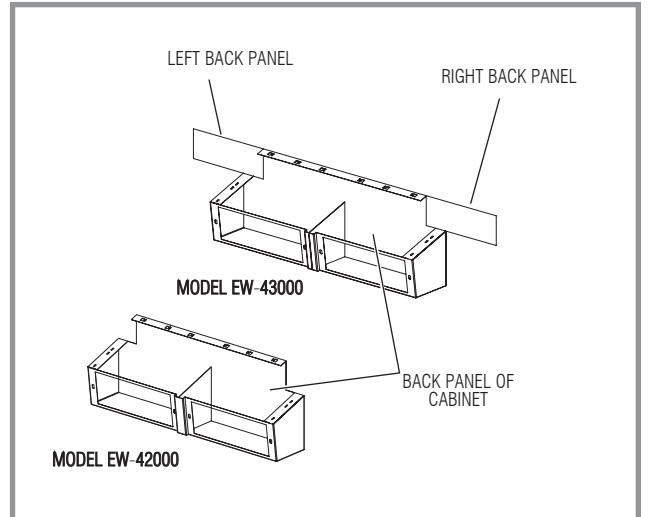

Step 3 — Basin and Actuator Housing Assembly

- A** Slide two ¼"-20 Tinnerman nuts into two center slots on top flange of Cabinet.
- Note: nuts should be approximately in center of slots.*
- B** With the help of an assistant, carefully lift Basin onto Cabinet aligning mounting holes in Basin with Tinnerman nuts of Cabinet.
 - C** Insert Left and Right Side Closure Panels between Cabinet and Basin as illustrated.
- Caution: Do not leave basin on cabinet unsupported. It may fall and cause damage or personal injury.*
- D** Align slots of Left Side Closure Panel with slots of Left Side Back Panel. Install ¼"-20 x ½" fasteners loose enough for further alignment. Follow the same procedure for the right side.
 - E** From beneath Basin, align slots of Cabinet and Closure Panels with threaded mounting holes beneath Basin. Install ¼"-20 x ½" fasteners in all Basin mounting holes and tighten securely. Tighten all remaining fasteners securely.
 - F** Locate front panel of Cabinet kit, align holes with front inserts on Basin and secure with ¼"-20 x ½" fasteners.
 - G** Place Actuator Assemblies on top of Basin with holes aligned. Secure each Actuator Assembly with two (2) ¼"-20 x ½" fasteners in rear holes.

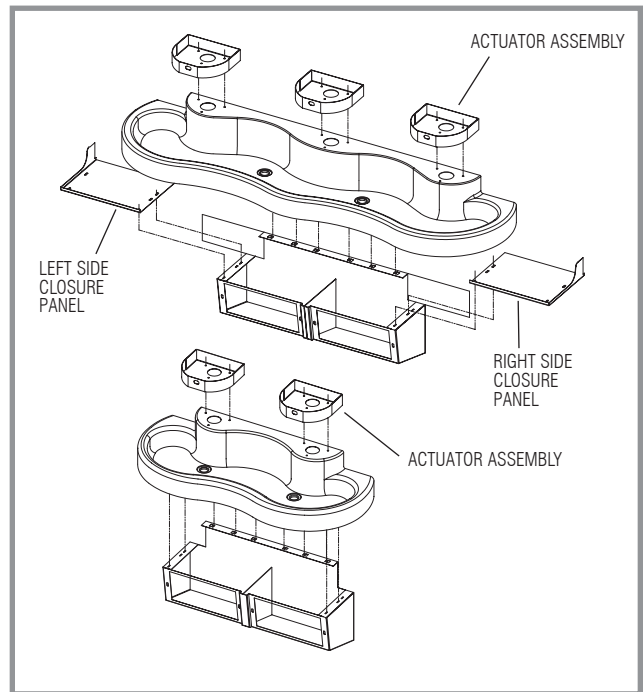

Step 4 — Sensor and Water Line Connection

- A** Locate group of colored wires attached to Terminal Block of Cabinet. Feed two like-colored wires into each Actuator Assembly.
- Note: Use wire tie mounts and wire ties to route and secure wiring. Wires are long enough to accommodate various routing paths. Longer wires may need to be bundled with wire ties so they do not come in contact with sharp corners.*
- B** Attach both like-colored wires to Sensor (either wire will work on each connector).
 - C** Locate the 3/8" x 4" colored tubing water lines. Match up the color of tubing with the color of wire and run tubing into each Actuator Assembly. Loosen Plastic Nut and firmly push each tubing water line onto Spray Head, being sure to match each color together (wire and tubing). Tighten Plastic Nut securely.

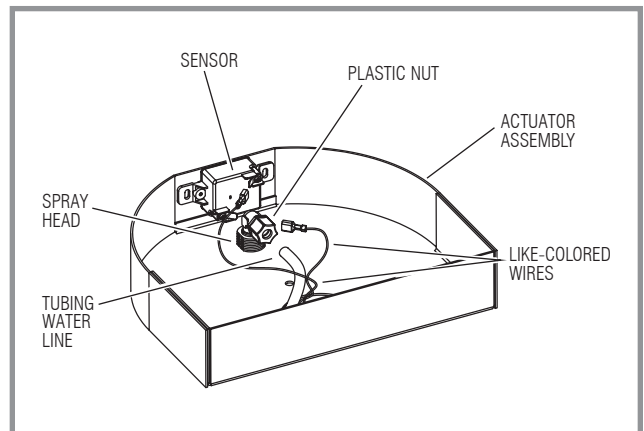

Step 5 — Drain and Water Supply Line Connection

- A** Install P-trap and drain lines making sure all connections are secure.
- Note: P-trap and drain lines furnished by others.*
- B** Flush supply line(s) of any debris. Install Flex Hose(s) to water supply line(s). Tighten fitting(s) securely.

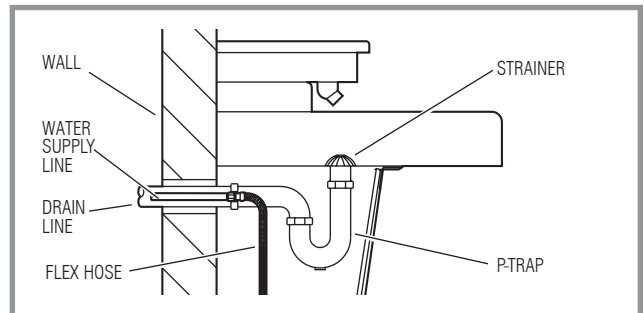

Step 6 — Supply Power to Lavatory System

- A** For hardwire installations, make sure that power is off to the transformer prior to making connections. Run power wires from Transformer to Terminal Block as illustrated. Use wire ties to secure wiring. Once all wiring within the system is connected, supply power to the Transformer.
 - B** For Plug-in Transformer installations, make sure that power is supplied to the receptacle. Once all wiring within the system is connected, plug the Transformer into the receptacle.
- Important: Plug-in Transformer MUST be used with a Ground Fault Interrupt (GFCI) Receptacle to help prevent possible electrical shock.*

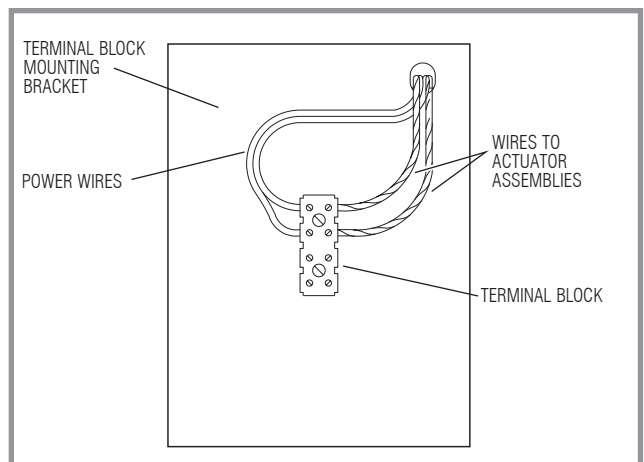

Step 7 — Start-Up

- A** Turn on water supply to lavatory system. Check for leaks at water supply and drain lines. Repair any leaks.
- B** With Aerator removed, activate Spray Head for 30 seconds by standing in front of the Spray Head. The Solenoid Valve should "click," Sensor LED indicator should blink and water should flow from the Spray Head. If this does not occur, refer to the Troubleshooting section of this instruction manual.
- C** Close Supply Stops and reinstall Aerator (using the Key provided). Reopen Supply Stops, activate Spray Head and check for leaks.

Optima EW-40000 Series Lavatory Systems are equipped with EL-1500-LL self adaptive infrared sensors. No adjustment is necessary. Spray head will operate when user is 25 to 45 inches (635 to 1143 mm) from the Sensor.

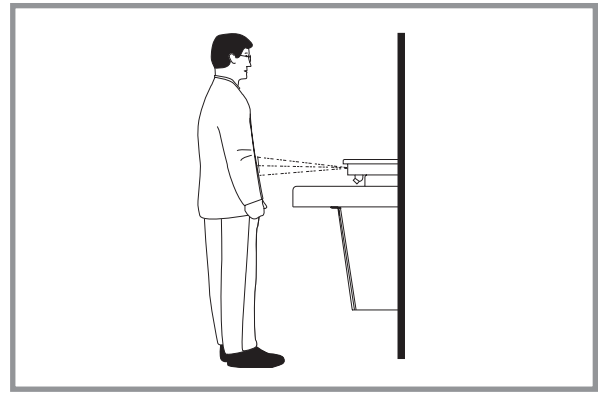

Step 9 — Final Assembly

- A** Slide a Tinnerman nut over the hole in each Filler Tray. Position Filler Trays between Actuator Assemblies.
- B** Install a 1/4"-20 x 1" hex bolt into the front hole of the Actuator Assembly and through the Basin. Secure using a Wing Nut. Follow the same procedure for the remaining Actuator Assemblies.
- C** Thread a Coupling Nut half-way onto one end of a Threaded Rod. Thread the other end of the Threaded rod through the Actuator Assembly and into the threaded hole of the Basin. The top of the Coupling Nut should be positioned just below the top of the Actuator Assembly. Install a Wing Nut onto the lower end of the Threaded Rod to secure the Threaded Rod from turning. Follow the same procedure for the remaining Actuator Assemblies.
- D** Position the Solid Surface Cover over the Actuator Assemblies aligning Cover mounting holes with Coupling Nuts.
- E** Install a 1/4"-20 x 1" flat head fastener through the Cover and into each Coupling Nut. Do not tighten fasteners at this time.
- F** Install a 1/4"-20 x 1 1/2" flat head fastener through the Cover and into each Filler Tray.
- G** Tighten all Cover fasteners at this time.
- H** Slide 1/4"-20 Tinnerman nuts over the remaining holes located on the front panel of the Cabinet. Install Solid Surface Front Access Panels with 1/4"-20 x 1" fasteners.

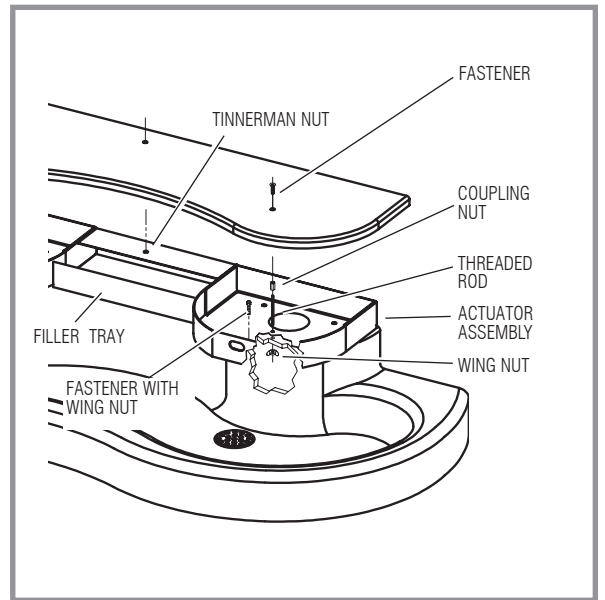

OPERATION

As the user enters the beam's effective range, the beam is reflected back into the sensor receiver and activates the solenoid valve allowing water to flow from the Spray Head. Water will flow until the user steps away from the Spray Head or until the automatic time out limit setting is reached.

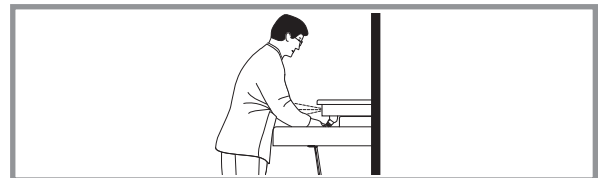

SOLENOID SCREEN FILTER CLEANING

- A** Before cleaning the Screen Filter, turn off the water supply at supply stop(s).
- B** Activate the Spray Head to relieve any pressure in the system.
- C** Unscrew the Filter Cap and remove it from the Solenoid Valve Housing.
- D** Carefully remove the Screen Filter from the Solenoid Valve Housing.
- E** Clean the Screen Filter using fresh tap water only. If necessary, use a small brush to clean. Use caution while cleaning to prevent damage to Screen Filter.
- F** Examine the Copper Washer for wear or damage; replace if necessary. Carefully replace the Screen Filter into the Filter Cap. Screw the Filter Cap with Copper Washer into the Solenoid Valve Housing and tighten securely to prevent leaks.
- G** Turn on the water supply at the supply stop(s). Activate the Spray Head to purge any air from the system lines. Check for leaks and repair as necessary.

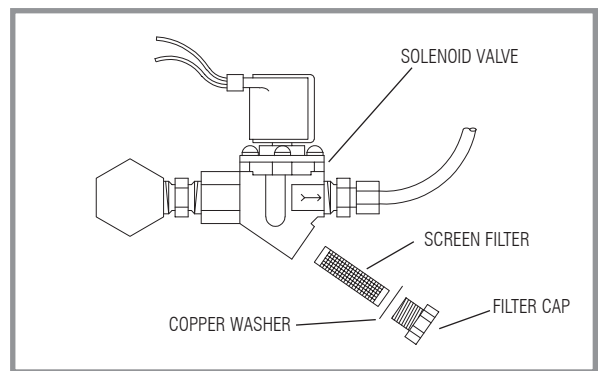

TROUBLESHOOTING GUIDE

I. No water flows when sensor is activated

Ensure that main power supply is turned "ON." Check receptacle, transformer, solenoid, leads and connections.

If Sensor LED does not blink:

- A. Control module circuit board is faulty; replace.
- B. Sensor is faulty; replace sensor module.

If Sensor LED blinks when user is sensed:

- A. Supply Stop(s) may be closed; open Supply Stop(s).
- B. Debris may be in Solenoid filter; remove, clean and reinstall.

II. Very low flow or slow dribble

- A. Supply Stop(s) may be closed; open Supply Stop(s).
- B. Debris is in solenoid, won't close properly; remove operator and clean. Reassemble in the same manner.
- C. Debris may be in Solenoid filter; remove, clean and reinstall.
- D. Debris is in spray head; remove, clean and reinstall.

III. Continues to run (even after power to faucet has been disconnected)

- A. Solenoid valve is installed backwards; install correctly.
- B. Debris is in solenoid, won't close properly; remove operator and clean. Reassemble in the same manner.

If further assistance is required, please contact the Sloan Valve Company Installation Engineering Department at 1-888-SLOAN-14 (1-888-756-2614).

PARTS LIST

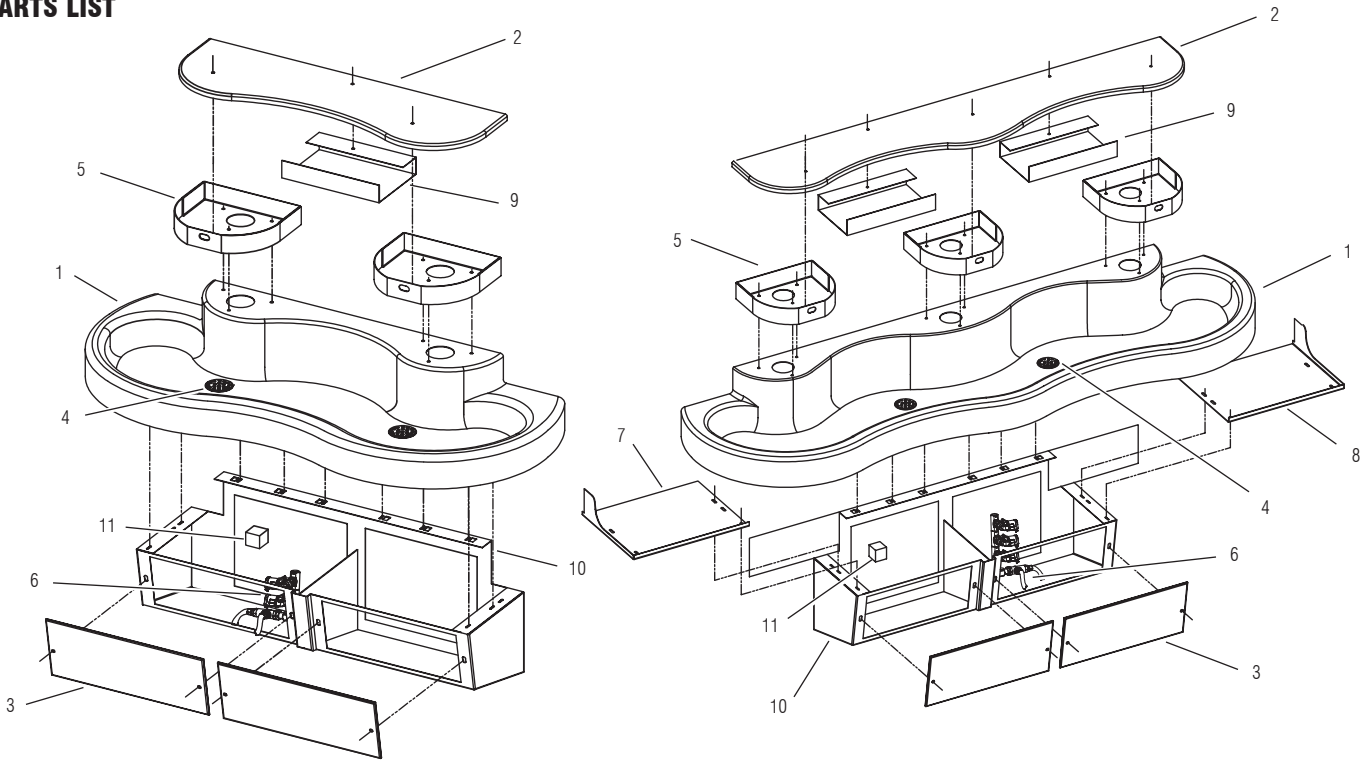

Hardware Kit

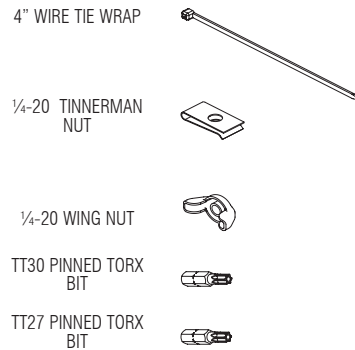
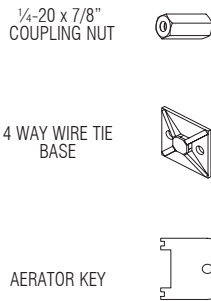
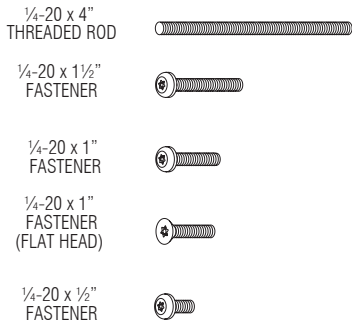

Item No.	Description
1	Solid Surface Basin
2	Solid Surface Top Cover
3	Front Panels
	Front Panels (LP)
4	Strainer Assembly
5	Actuator Assembly
6	Electronic Valve Assembly
7	Left Side Closure Panel
8	Right Side Closure Panel
9	Filler Tray
	Soap Tray
10	Cabinet (LP)
	Cabinet (Standard)
	Cabinet (Floor Mounted)
11	Power Supply
	Hardware Kit

Part No.	Description
	MIXING VALVE
	MIX-135-A Below Deck Thermostatic Water Mixing Valve (BDT Variation)
	SENSOR REPLACEMENT KIT
	EL-1500-LL
	SOLENOID REPLACEMENT KIT
	ETF-408
	SOLENOID FILTER REPLACEMENT KIT
	ETF-1009-A

NOTICE:

The information contained in this document is subject to change without notice.